

Instruction Manual

PLATFORM STACKER

Model: PJ,PF Series

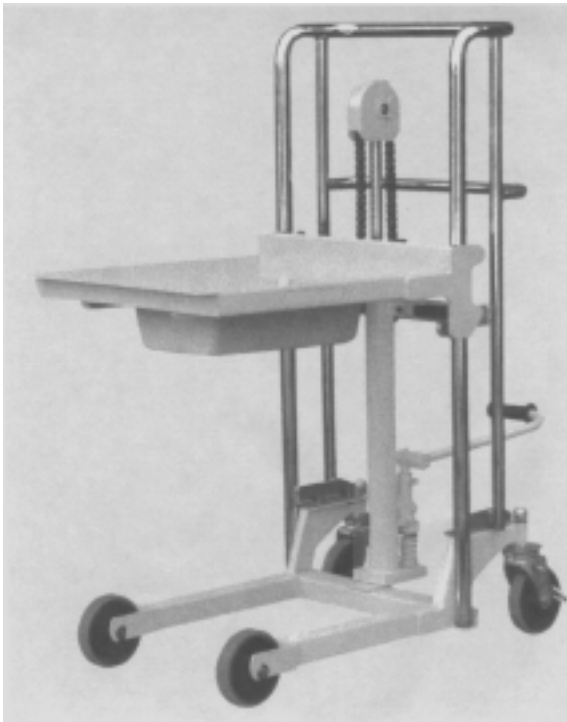

Note: Owner/Operator must read and understand this instruction manual before using the platform stacker.

CONTENTS

Nomenclature of Each Section

Attention

Operation Instructions

Daily Care

Periodical Inspection

How to Assemble

Safety Instruction

Exploded Figure and Parts List

Nomenclature of Each Section

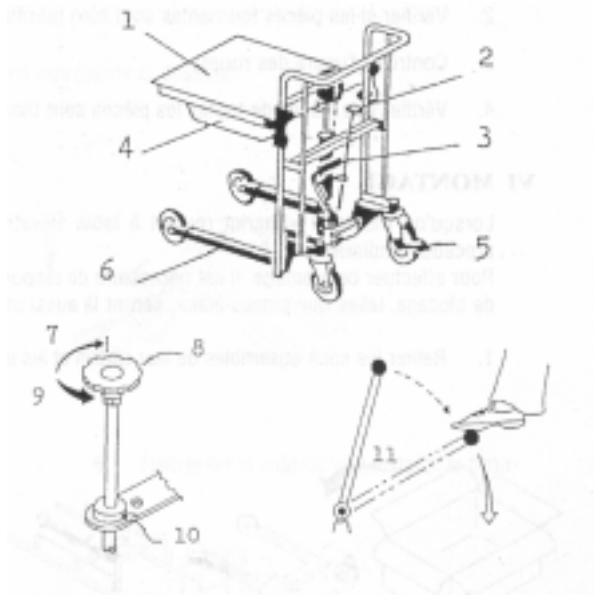

1. Table
2. Lowering Valve
3. Foot Pedal (Pumping Pedal)
4. Drawer (Low Profile without Drawer)
5. Brake
6. Chassis
7. Lift
8. Lowering Valve
9. Lower

10. Stopper
11. Foot Pedal (Pumping Pedal)

Attention

1. Use it on a level paved road. If it is driven on a level road, the wheels are not damaged and can be operated lightly.
2. Don't overload it beyond the prescribed maximum load.
3. When putting a load on the table, don't load it biased, for instance, on one side or at the fore end of the table.

Operation Instructions

1. Raise (Lift) of the table.

Tighten the lowering valve (by turning it clockwise), put down the foot pedal and work it. Then the table will lift up.

2. Lowering of the Table.

Loosen the lowering valve (by turning it counter-clockwise), and then the Table will lower down.

3. Lowering speed of the Table can be adjusted according to the degree it is turned.

4. Range of lowering speed adjustment.

In order to prevent abrupt lowering of the Table when loading goods, the Truck is provided with stopper. When the lowering speed is too quick or too slow, adjust the position of this

stopper.

Daily Care

1. If the load chain is corroded, it becomes weak and dangerous, so always lubricate it by applying grease.
2. Unless oil leaks from the pump. It is not necessary to supply oil for about half a year to one year.
3. Usually, when changing oil or replenishing oil, use L-HL68 Hydraulic oil (equivalent to ISO VG68). If temperature is between -15°C -- -5°C , Please use L-HL46 Hydraulic oil (equivalent to ISO VG68).

Periodical Inspection

1. Inspect the chain fixing nut for looseness.
2. Check whether the rotating parts are well lubricated or not.
3. Inspect the wheels for wear.
4. Inspect the screw in each part for looseness.

How to Assemble

When assemble "Platform Stacker" do so securely, taking the following step.

When assembling it, two spanners 13 and two spanners 17 are required.

Clamping tools, such as monkey wrenches will do as well.

1. Take the assemblies from the carton box and disassemble them in the order of (a), (b), (c), (d) and (e), as follow:



Carton Box (a); Chassis (c); Handle (c); Table (d); Drawer (e); Bolt & Nut

Lay the handle on the floor as shown in the Figure below.

2. Put the Table into the Handle.

Attention! Put it between the two rollers of the table.

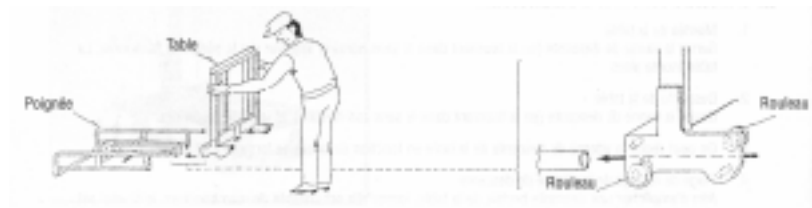

3. Attach the Chain. Fasten the unit with the nut tightly.



4. After attaching the chain, invert the unit as shown in the Figure below.

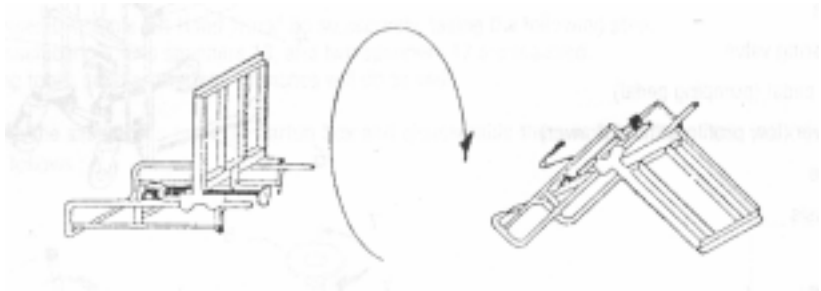

5. Fasten the chasis with 4 bolts securely. Put the pin into the hole in the pump.

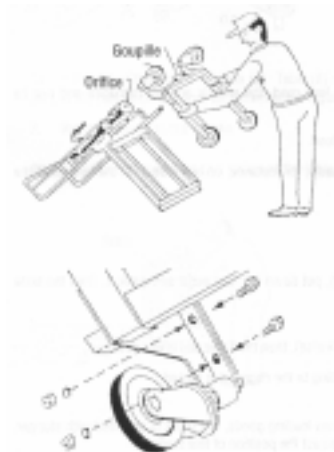

6. Erect the chasis and put it into the Drawer.

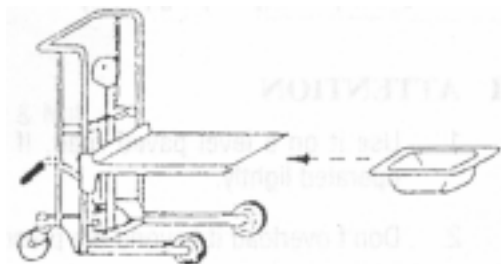

Safety Instruction

1. Safety Rules

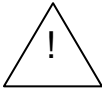

Warning

Failure to obey the instructions and safety rules in this manual may result in death or serious injury.

1.1 Do Not Operate Unless:

- 1) You learn and practice the principles of safe machine operation contained in this operating manual.
 - — Avoid hazardous situations.
 - — Always perform a pre-operation inspection.
 - — Always perform the function tests prior to use.
 - — Inspect the workplace.
 - — Only use the machine as a material lift.

2) You read, understand and obey:

- — Manufacturer's instructions and safety rules
- — Employer's safety rules and worksite regulations
- — Applicable governmental regulations

1.2 To Avoid Hazardous Situations:

1) Fall Hazard

Do not use a personnel lifting platform or step.

2) Tip-over Hazards

Do not overload the winch stacker.

Do not raise the load unless the machine is on a firm, level surface.

Do not move the machine with a raised load, except for minor positioning.

Do not tilt the machine back with a raised load.

Do not operate the machine in strong or gusty winds.

Prior to use, check the work area for drop-offs, holes, bumps, debris, unstable surfaces or other possible hazardous conditions.

Do not subject the machine to horizontal force by raising or lowering a fixed or overhanging load.

User refer to prEN1005-3 for further guidance.

If the load exceeds the actual operational capacity, the operator must be assisted by one or more persons.

The machine can be only used in the light environment of at least 50LUX.

3) Collision Hazards

Do not lift if the load is not properly centered on the forks.

Check the work area for overhead obstruction or other possible hazards.

Do not stand under or allow personnel under the machine when the load is raised.

Do not lower the load unless the area below is clear of

personnel and obstructions.

4) Bodily Injury Hazards

Do not grasp the cable.

Keep hands and fingers away from pulleys, the carriage and other potential pinch points.

Recommended operators to wear safety shoes and gloves.

Do not put the feet under the forks to avoid any damages when using the machine.

5) Improper Use Hazard

Never leave a machine unattended with a load. Unauthorized personnel may attempt to operate the machine without proper instruction, creating an unsafe situation.

6) Damaged Machine Hazards

Do not use a damaged or malfunctioning machine.

Do not use a machine with a worn, frayed, kinked or damaged cable.

Do not use a machine with less than 4 wraps of cable on the winch drum when the carriage is fully lowered.

If you see the red mark on the cable, at least 4 wraps are on the winch drum.

Conduct a thorough pre-operation inspection prior to each use.

Be sure that all decals are in place and legible.

Maintain proper lubrication of the winch.

7) Crushing Hazard

Do not release grasp on the winch handle until the brake is locked.

8) Lifting Hazard

Use proper lifting techniques to load or tip the machine.

9) Other items

When pushing the machine on the rough floor the force will be bigger.

To avoid overloading, the operating force will increase and reach to 400N when reaching to the nominal load.

Pay attention to the balance of the goods to avoid their turning over when lifting them.

Do pay attention to avoid the goods turn over towards the back when using the machine on a slope.

Item No.	Description	Qty.
1	Hand Rack	1
2	Nut	2
3	Washer	2
4	Nut	2
5	Bolt	4
6	Nut	4
7	Retain Pin	4
8	Bolt	4
9	Washer	4
10	Roller	4
11	Bearing	4
12	Roller Pin	4
13	Base for fork	1
14	Shaft	1
15	Retaining Ring	2
16	Bush	2
17	Fork	2
18	Platform	1
19	Pin	2
20	Retaining Ring	4
21	Retaining Ring	4
22	Bearing	4
23	Front Wheel	2
24	Chassis	1
25	Nut	2
26	Washer	2
27	Steering Wheel	2
28	Screw	2

29	Washer	2
30	Spring	4
31	Steel Ball	2
32	Bolt	2
33	O-ring	2
34	Screw	1
35	Spring	1
36	Pin	1
37	Link Plate	1
38	Locating Plate	1
39	Spring	1
40	Screw	2
41	Locating Ring	2
42	Shaft	1
43	Revolving Ring	1
44	Pin	2
45	Chain Bolt	2
46	Chain	1
47	Chain Wheel Cover	1
48	Bearing	1
49	Chain Wheel	1
50	Pin	1
51	Retaining Ring	2
52	Chain Wheel Cover	1
53	Nut	2
54	Bolt	2
55	Piston Rod	1
56	Dustproof Ring	1
57	O-ring	2

58	Retaining Ring	1
59	Internal Bush	1
60	Pump Rod	1
61	Internal Cylinder	1
62	Pump Spring Cover	1
63	Sealing Plate	1
64	Pump Spring	1
65	Locating Lug	2
66	Cylinder Pin	1
67	Valve Core	1
68	O-ring	2
69	Pipe	1
70	External Cylinder	1
71	Pump body	1
72	Dustproof Ring	1
73	O-ring	2
74	Retaining Ring	1
75	Pump Bush	1
76	Oil Holder	2
77	Pin	1
78	Pump Base Nut	1
79	Nut	1
80	Pin	1
81	Pump Pressure Roll	1
82	Bearing	1
83	Steel Ball	1
84	Bearing Bush	1
85	Bar	1
86	Rubber Bush	1

PF Series

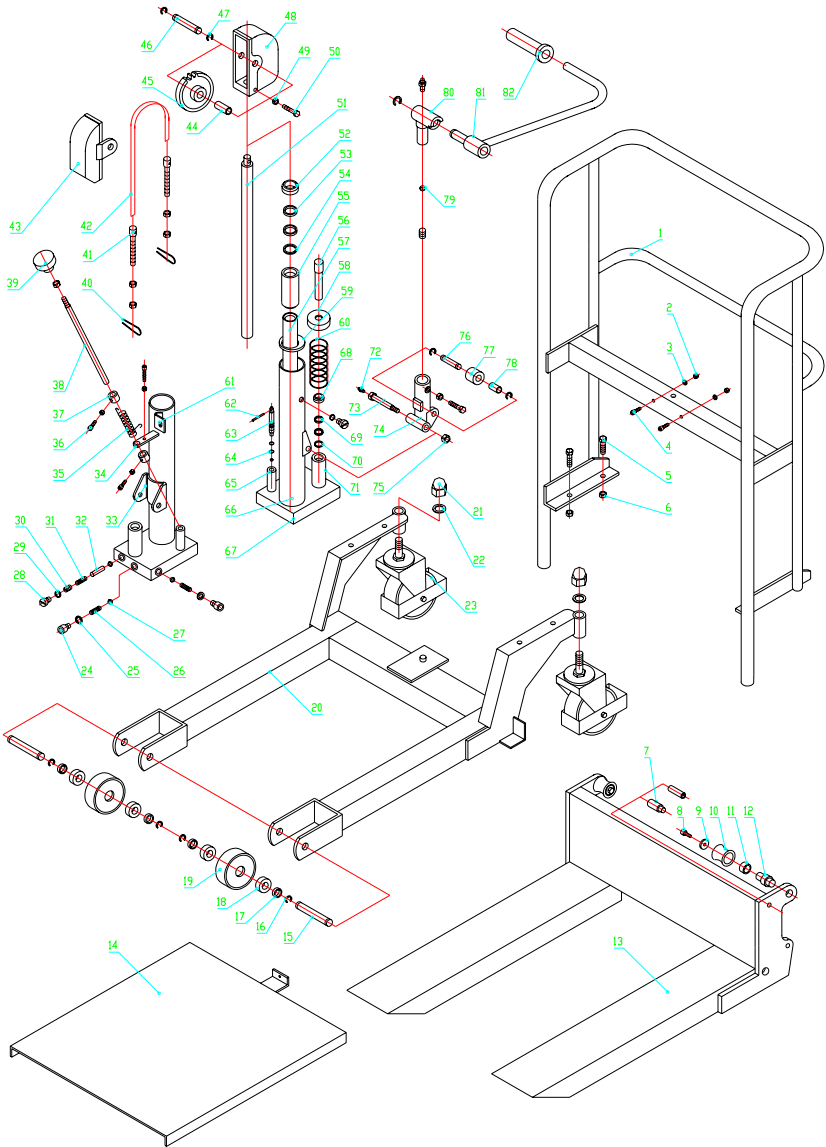

Part No.	English Description	Qty
1	Handle Rack	1
2	Nut	2
3	Washer	2
4	Bolt	2
5	Bolt	4
6	Nut	4
7	Retain Pin	4
8	Bolt	4
9	Washer	4
10	Roller	4
11	Bearing	4
12	Roller Pin	4
13	Fork	1
14	Adjustable Platform	1
15	Pin	2
16	Retaining Ring	4
17	Retaining Ring	4
18	Bearing	4
19	Front Wheel	2
20	Chassis	1
21	Nut	2
22	Washer	2
23	Steering Wheel	2
24	Screw	2
25	Washer	2
26	Spring	4
27	Steel Ball	2
28	Bolt	2
29	O-Ring	2
30	Screw	1

31	Spring	1
32	Pin	1
33	Link Plate	1
34	Locating Plate	1
35	Spring	1
36	Screw	2
37	Locating Ring	2
38	Shaft	1
39	Revolving Ring	1
40	Pin	1
41	Chain Bolt	1
42	Chain	1
43	Chain Wheel Cover	1
44	Bearing	1
45	Chain wheel	1
46	Pin	1
47	Retaining Pin	2
48	Chain Wheel Cover	1
49	Nut	2
50	Bolt	2
51	Piston rod	1
52	Dustproof Ring	1
53	O-Ring	2
54	Retaining Ring	1
55	Internal Bush	1
56	Pump Rod	1
57	Internal Cylinder	1
58	Pump Spring Cover	1
59	Sealing Plate	1
60	Pump Spring	1
61	Location Lug	2
62	Cylinder Pin	1

63	Valve Core	1
64	O-Ring	2
65	Pipe	1
66	External Cylinder	1
67	Pump Body	1
68	Dustproof Ring	1
69	O-Ring	2
70	Retaining Ring	1
71	Pump Bush	1
72	Oil Holder	1
73	Pin	1
74	Pump Base	1
75	Nut	1
76	Pin	1
77	Pump Pressure Roll	1
78	Bearing	1
79	Steel Ball	1
80	Bearing Bush	1
81	Bar	1
82	Rubber Bush	1
83	Pump Unit	1